



cULus Approved for Wet Locations

Available with up to 4000 Lumen LED Array

SPECIFICATIONS:

- Housing constructed of heavy-duty die-cast aluminum, finished in Duraplex II™ Electrostatic Powder coat.
- Integrated cast aluminum heat management system is manufactured as a part of the lens frame assembly for maximum heat dissipation and exposure to outside air flow resulting in cooling of electronics and long life. Painted to match housing with Duraplex II™ Electrostatic Powder coat.
- Pre-mountable wall box with integral splice chamber and hands free fixture to wall positioning for wiring. Built in bubble level for installation accuracy. Direct mounting orientation only with 0 degree and 22 degree tilt. Not approved for 45 degree tilt or Indirect installations.
- Aluminum backed printed circuit board featuring Lumileds Luxeon Rebel Neutral White LED's, 4000K colour temperature, 65 CRI. The custom LED board includes specially designed tracings for efficient heat dissipation, and includes end of life isolation for individual LED's.
- Electronic LED driver, Class II, with Constant Current ensures all LED's are operated consistently and are regulated with proper electrical characteristics over their entire life. The driver features include: THD < 20%, high level of voltage regulation, high power factor > 0.95, -30°C minimum start temperature, and built in thermal protection to prevent system from overheating. Additional protection includes 10kV surge protector.
- LED's are situated in patented asymmetric collimating optics that are individually oriented to provide type 2, 3, and 4 distribution patterns.
- LED's are protected by a tempered flat glass lens sealed with gasketing to provide a clean dust tight optical assembly.
- Expected life of 60,000 hours with 70% lumen maintenance (L70) and designed to meet LM-79 & LM-80 standards.
- Environmentally friendly construction using RoHS compliant components (lead, mercury and cadmium free), POP (Persistent Organic Pollutants) free, and VOC (Volatile Organic Pollutants) free.
- IES full cut-off and semi cut-off classifications providing night friendly lighting options.

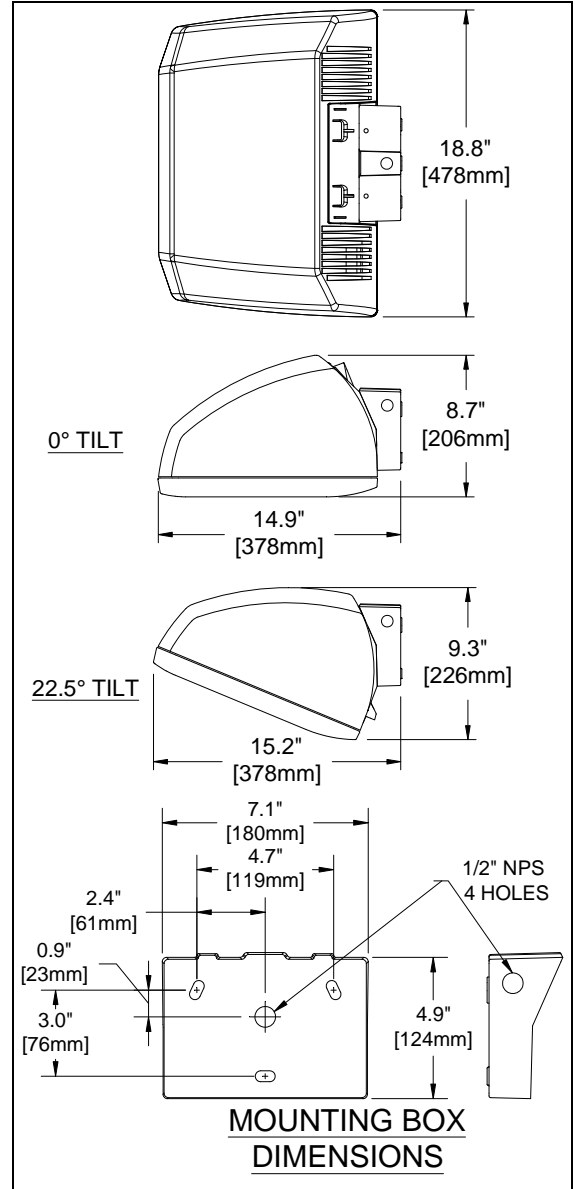

Electrical Characteristics				
Lumens	120 - 277V		347V	
	Input Wattage	Input Current	Input Wattage	Input Current
4000 lm	100W	0.88 - 0.38A	105W	0.32A
3000 lm	66W - 70W	0.58 - 0.30	71W	0.22A

ORDERING GUIDE:

Example: **NXFPL4040X2LEDA2-6W**

NXFP	L		40	X		LED	A2	-	
Series	Size	Lumens	Colour Temp	Optics	Distribution Type	Source	Version Code	Voltage	Colour
NXFP : NextLED FloodPak	L : Large	40 : 4000 lm 30 : 3000 lm	40 : 4000K	X : NextLED	2 : Type 2 3 : Type 3 4 : Type 4	LED	A2 (factory preset)	1 : 120V 2 : 208V 3 : 240V 4 : 277V 6 : 347V	P : Bronze W : White G : Grey B : Black Consult factory for additional colours

PROJECT: _____

TYPE: _____ CATALOGUE NUMBER: _____